

- Version 01, Year 2024 -



wupatec

DESIGN CAPABILITIES

**Innovative Solutions for Wireless and
Space Communications**

UPDATED 17.09.2024

**“ Unlocking
Efficiency
in Wireless
Communication
Systems ”**

-Wupatec

CONTENTS

ABOUT WUPATEC	03
SECTION 01	
POWER AMPLIFIER	04 - 27
SECTION 02	
AMPLIFIER MODULES	28 - 29
SECTION 03	
TEST PLATFORMS	30 - 34
COMPLETE CONFIGURATION	35

About **WUPATEC**

Wupatec is a startup that specializes in RF amplifier solutions and front-end optimization. With extensive 5G NR technology expertise and space industry experience, we are uniquely positioned to meet the most demanding requirements of a constantly changing world.

Wupatec's combined knowledge in the digital and RF domains allows us to overcome the typical limitations of combining these fields of knowledge. Our added value is that RF and digital engineers work hand-in-hand throughout the whole design process, resulting in effective, innovative, and reliable results. By solving challenges such as energy consumption and spectral efficiency, Wupatec creates a path to the evolution of new space technology.

We are headquartered in France, with teams in Toulouse and Limoges.

Experience the difference with Wupatec - where efficiency meets innovation

Partnership

We recognize that partnership and collaboration are essential for success in the fast-paced 5G era. As a result, Wupatec works with a number of global partners to deliver its differentiated products. If you are interested in exploring opportunities to collaborate and create value together, please contact us at contact@wupatec.com.



SECTION 01

POWER AMPLIFIERS

Our versatile range of power amplifiers, designed for telecom, radar, and space applications, showcases our expertise across the main 5G frequency bands. Each prototype in this catalogue, which includes a PCB mounted on copper or aluminum, is specifically designed for telecom use cases during conference demonstrations to highlight our exceptional design capabilities.

Wupatec's engineering team can design in any frequency band based on the client's specifications. Wupatec distinguishes itself from the competition by being adaptable to the client's needs and delivering a precise final product in a timely manner.

To meet size, cost, and reliability requirements, all designs can be manufactured using monolithic microwave integrated circuit (MMIC) technology, a QFN-style package, or the required PCB size.

We are proud to serve leading clients in the telecommunications and defense sectors. Their trust reflects our dedication to delivering reliable, high-performance solutions that excel in even the most demanding environments.

WHY DOHERTY ?

The interest in a Doherty power amplifier lies in its ability to deliver high efficiency, particularly at back-off power levels, which are commonly encountered in modern communication systems.

The Doherty architecture addresses this combining two amplifiers - main amplifier and peak amplifier - in a way that maintains high efficiency across a wide range of output powers. This is particularly important for applications such as mobile base stations, where energy consumption is a critical concern. The result is improved overall efficiency, reduced power consumption, and lower operating costs, making Doherty power amplifiers a key technology in the pursuit of more sustainable and cost-effective wireless communication systems.

Our team of design engineers specializes in the design of RF Doherty power amplifiers to meet the growing demand for high-efficiency, high-performance RF solutions in wireless communication systems. By concentrating on this niche, Wupatec can provide customized, state-of-the-art solutions that satisfy customers' demands for RF power amplifiers that are more effective, affordable, and scalable, thereby strengthening their competitive edge in quickly changing markets like 5G and beyond.

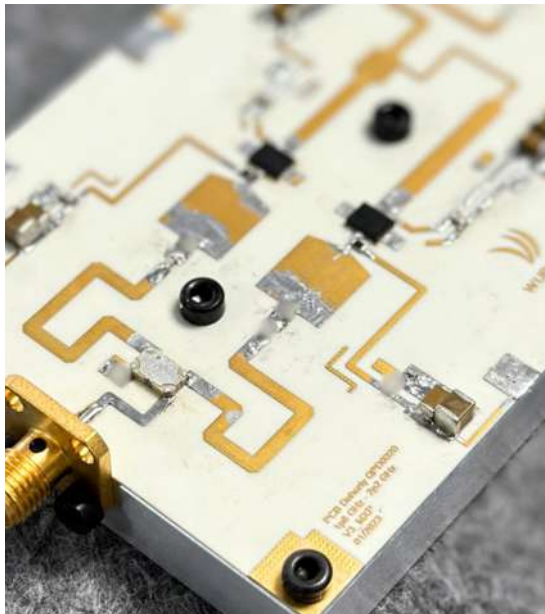

DOHERTY 1.8 – 2.2 GHZ

- GaN on SiC Doherty PA
- Frequency range: 1.8GHz – 2.2GHz
- Drain efficiency: >46% at 8dB Output Back Off (OBO)
- Output power at P3dB = 47.5 dBm
- Power gain: 18 dB
- Board size: 80 x 60 mm

[*page 7*](#)

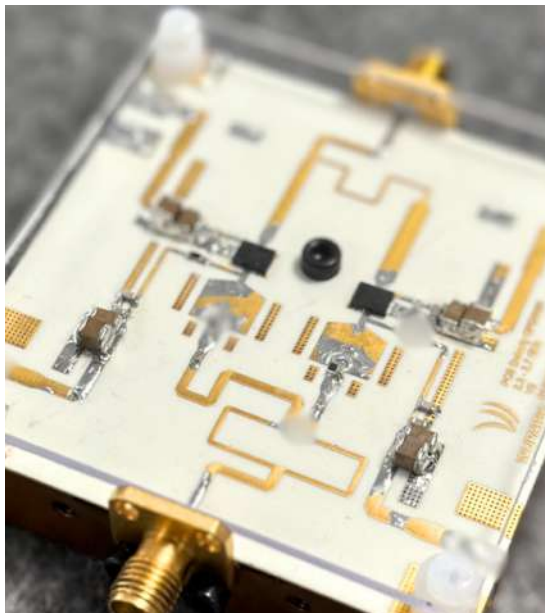

DOHERTY 2.3– 2.7 GHZ

- GaN on SiC Doherty PA
- Frequency range: 2.3GHz – 2.7GHz
- Drain efficiency: >45% at 8dB Output Back Off (OBO)
- Output power at P3dB = 47.5 dBm
- Power gain: 15 dB
- Board size: 60 x 60 mm

[*page 9*](#)

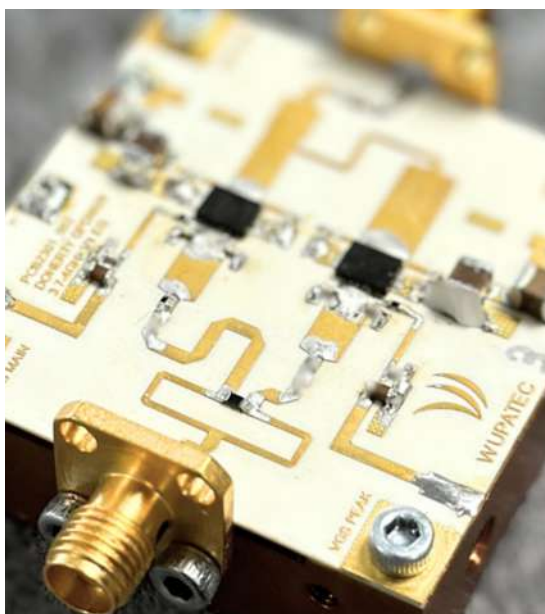

DOHERTY 3.7 - 4.2 GHZ

- GaN on SiC Doherty PA
- Frequency range: 3.7GHz – 4.2GHz
- Drain efficiency: >46% at 8dB Output Back Off (OBO)
- Output power at P3dB = 47.5 dBm
- Power gain: 12 dB
- Board size: 40 x 40 mm

[*page 13*](#)

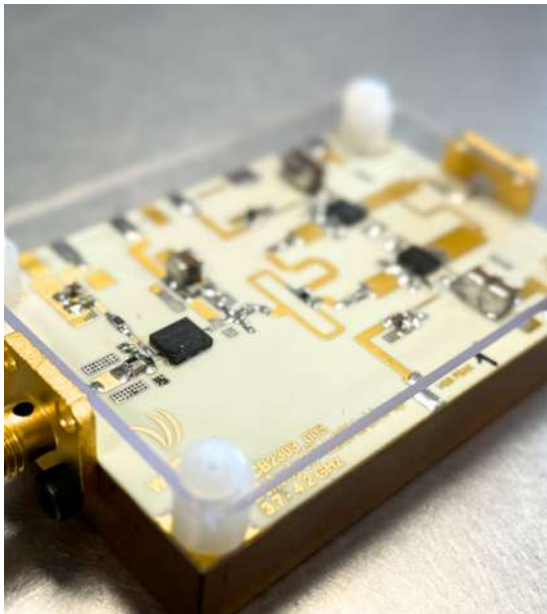

2 STAGE-DOHERTY

3.7 – 4.2 GHZ

- GaN on SiC Transistors, 2 stages
- Frequency range: 3.7GHz – 4.2GHz
- PAE: 42% at 8dB Output Back Off (OBO)
- Output power at P3dB = 47.5 dBm
- Power gain: 31 dB
- Board size: 60 x 40 mm

page 19

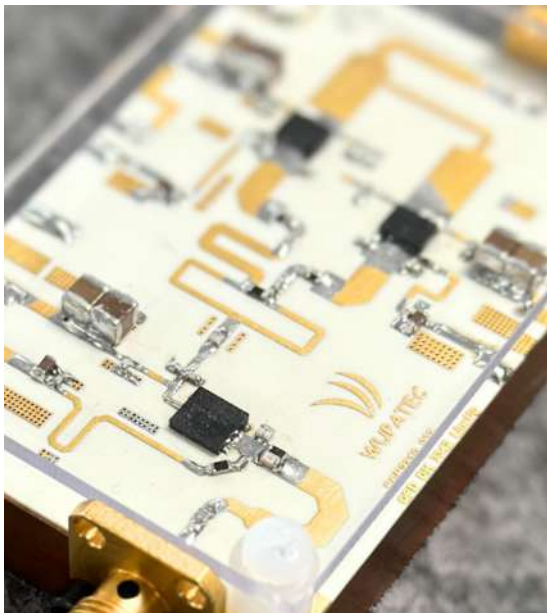

2 STAGE-DOHERTY

3.3 – 4.2 GHZ

- GaN on SiC Transistors, 2 stages
- Frequency range: 3.3GHz – 4.2GHz
- PAE: 35% at 8dB Output Back Off (OBO)
- Output power at P3dB = 47.5 dBm
- Power gain: 29 dB
- Board size: 60 x 40 mm

page 28

DOHERTY 1.8 – 2.2 GHZ

POWER AMPLIFIER KEY FEATURES

- *GaN on SiC Doherty PA*
- *Frequency range: 1.8GHz – 2.2GHz*
- *Drain efficiency: >46% at 8dB Output Back Off (OBO)*
- *Output power at P3dB = 47.5 dBm*
- *Power gain: 18dB*
- *Board size: 80 x 60 mm*

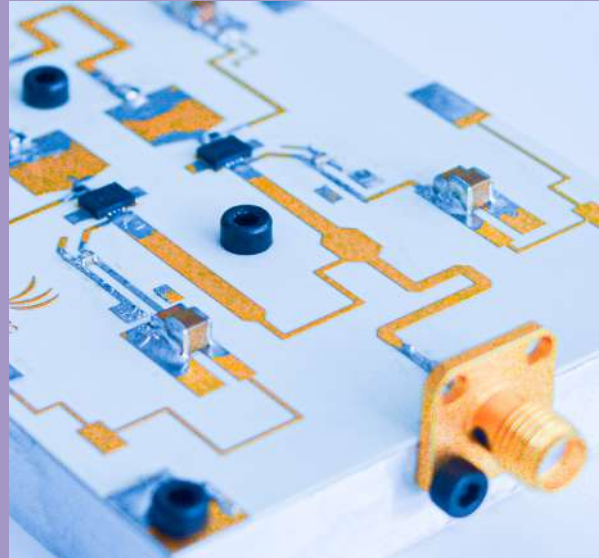

TYPICAL APPLICATIONS

- 3GPP 5G NR FR1 bands n1, n2, n3, n25, n30, n34 and n39
- 3GPP 4G LTE bands 1, 2, 3, 25, 34 and 39
- Frequency Division Duplex and Time Division Duplex systems
- Microcell Base Station
- Repeaters
- Small cells for wireless communications infrastructure
- Active antennas
- Land Mobile and Military Radio Communications
- General purpose wireless applications
- MIMO Applications



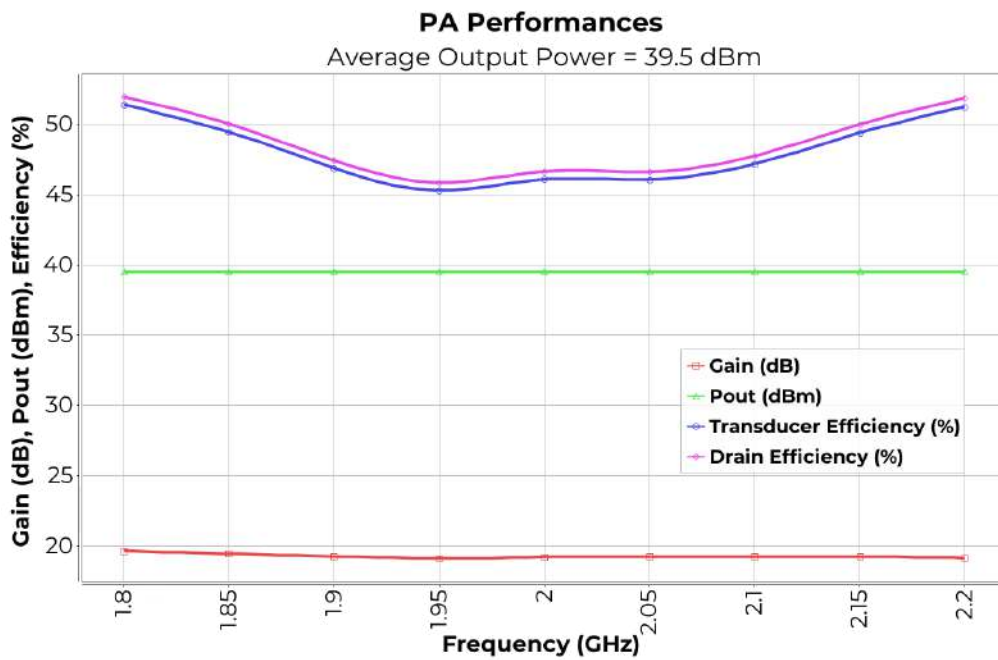
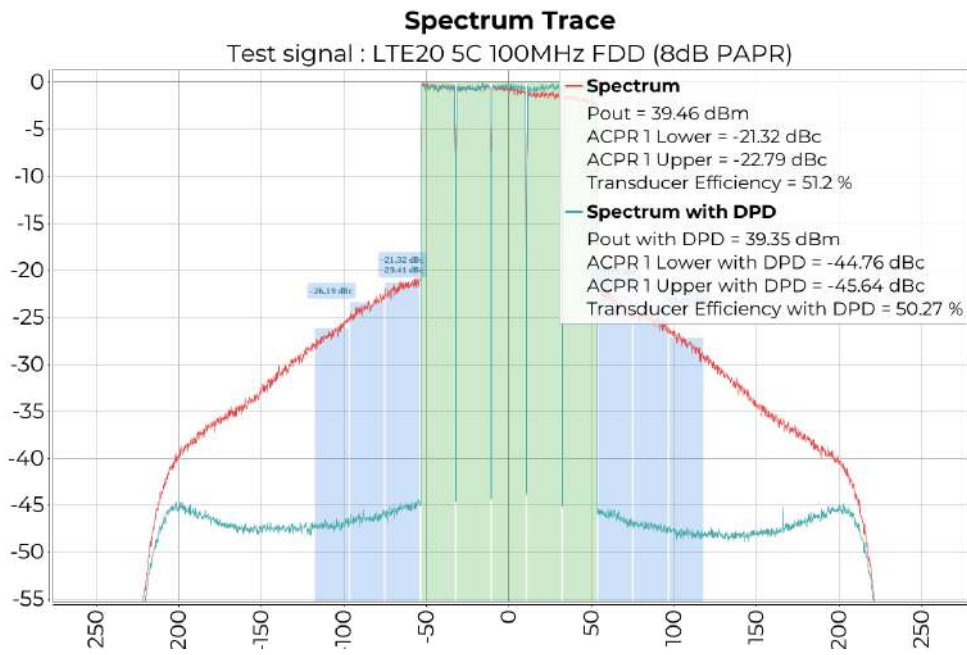

Test signal :

LTE20 5C 100MHz Frequency Division Duplex 8dB PAPR), Center Frequency = 2GHz

PA Performances at Average Power = 39.5dBm and PA spectrum at 2GHz

DOHERTY 2.3 – 2.7 GHz

POWER AMPLIFIER KEY FEATURES

- *GaN on SiC Doherty PA*
- *Frequency range: 2.3GHz –2.7GHz*
- *Drain efficiency: >45% at 8dB Output Back Off (OBO)*
- *Output power at P3dB = 47.5 dBm*
- *Power gain: 15dB*
- *Board size: 60 x 60 mm*

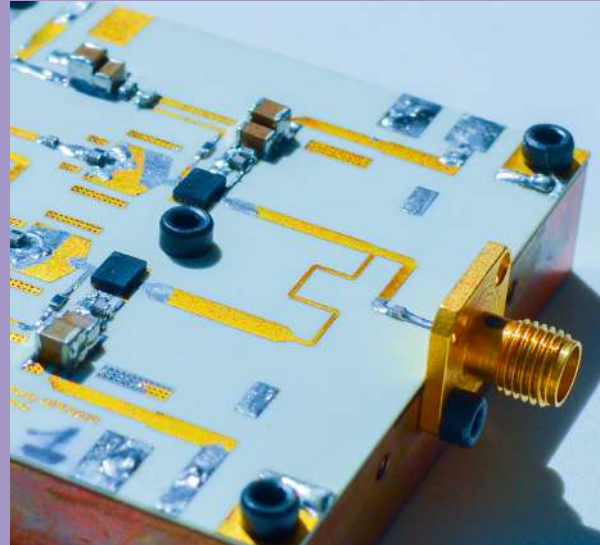

TYPICAL APPLICATIONS

- 3GPP 5G NR FR1 bands n7, n38, n40, n41, n77 and n78
- 3GPP 4G LTE bands 7, 38, 40, 41 and 69
- Frequency Division Duplex and Time Division Duplex systems
- Communication systems for emergency services
- Small cells for wireless communications infrastructure
- General purpose wireless applications
- MIMO Applications

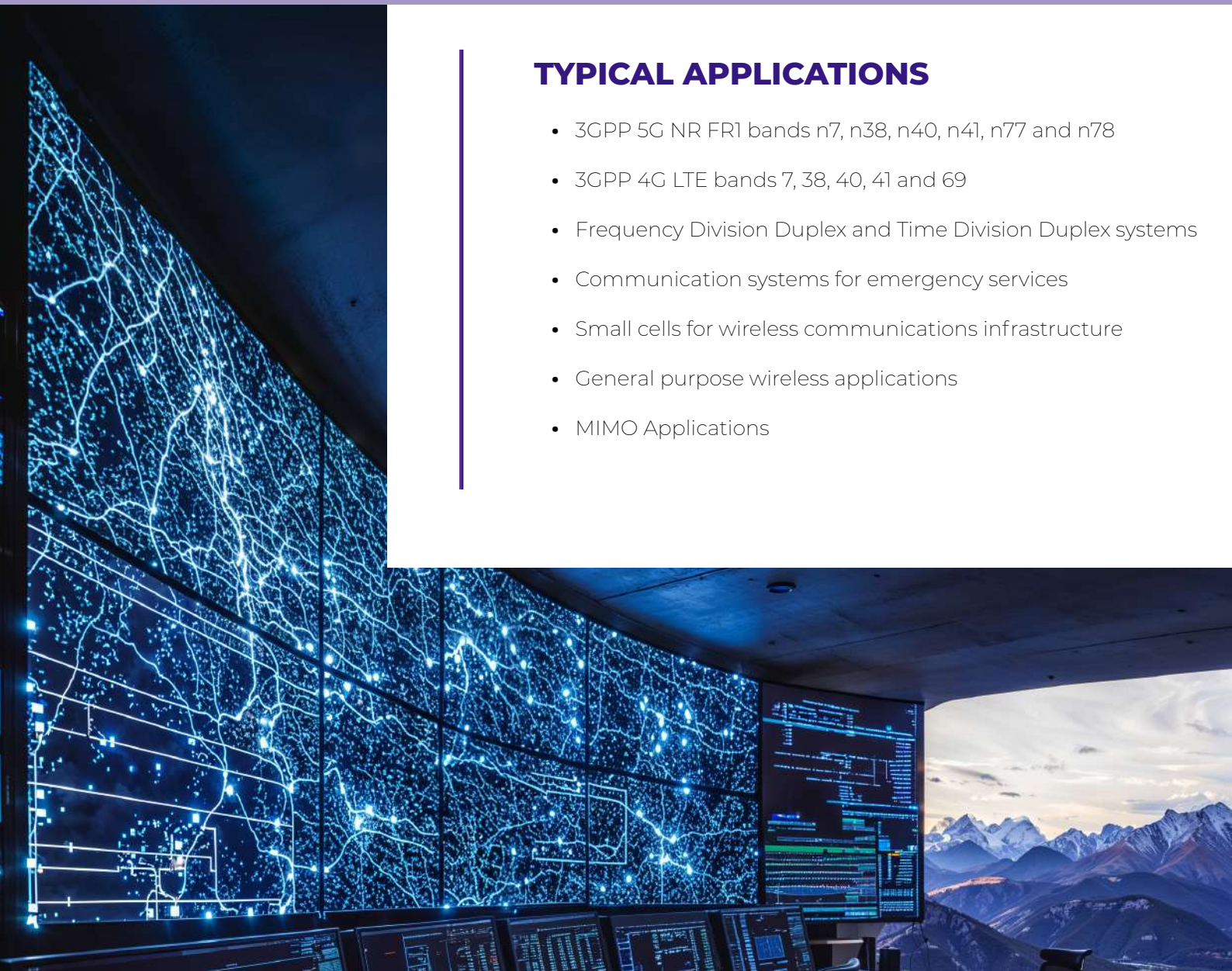



RF pulsed characterization: 100 μ s, 10% Duty Cycle Final Stage Drain Efficiency

PA Performances

RF Pulse Characterization: 100 μ s, 10% Duty Cycle

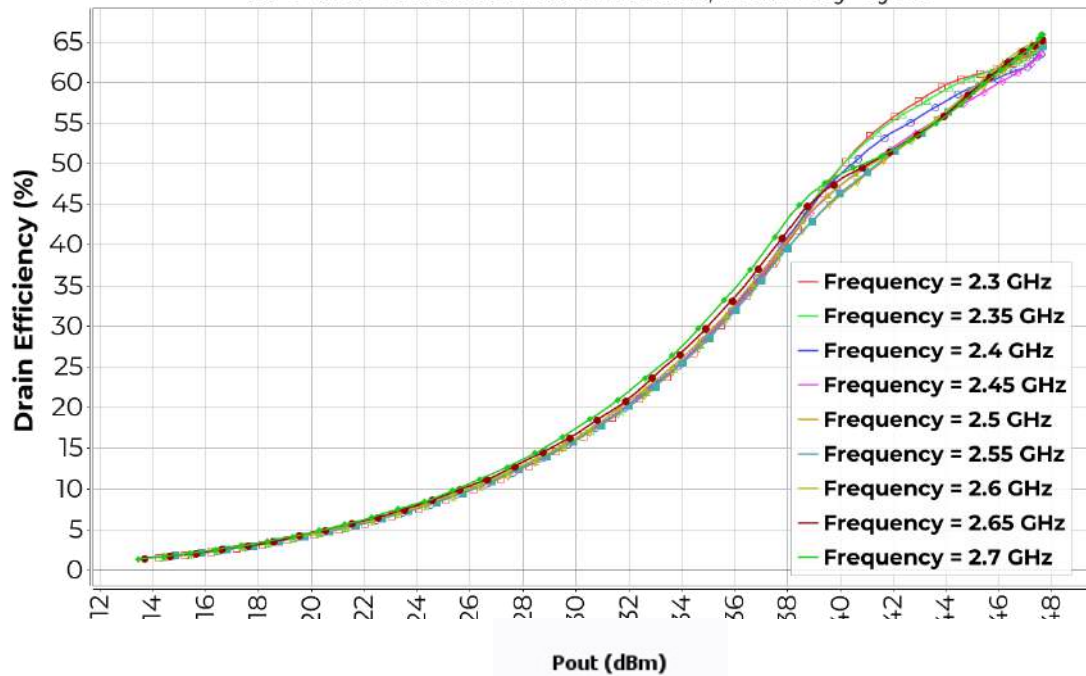

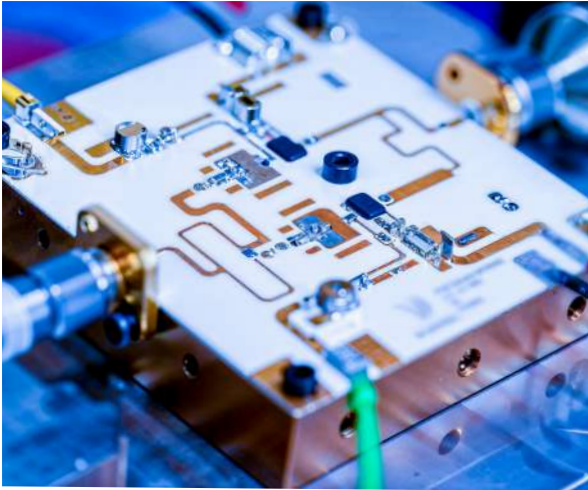

AMPLIFIER PERFORMANCES

- Test signal: 5G NR 100MHz 1C 100MHz Frequency Division Duplex (8dB PAPR)
- Pout = 39.5dBm
- **ADRV9009 test platform controlled by IQstar**

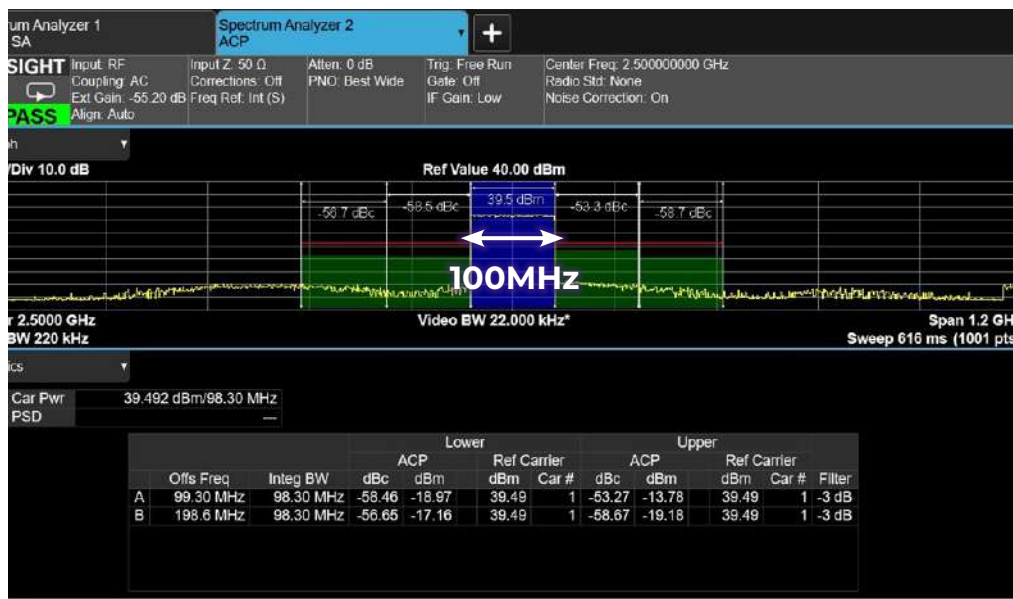

PA Performances

Average Output Power = 39.5 dBm

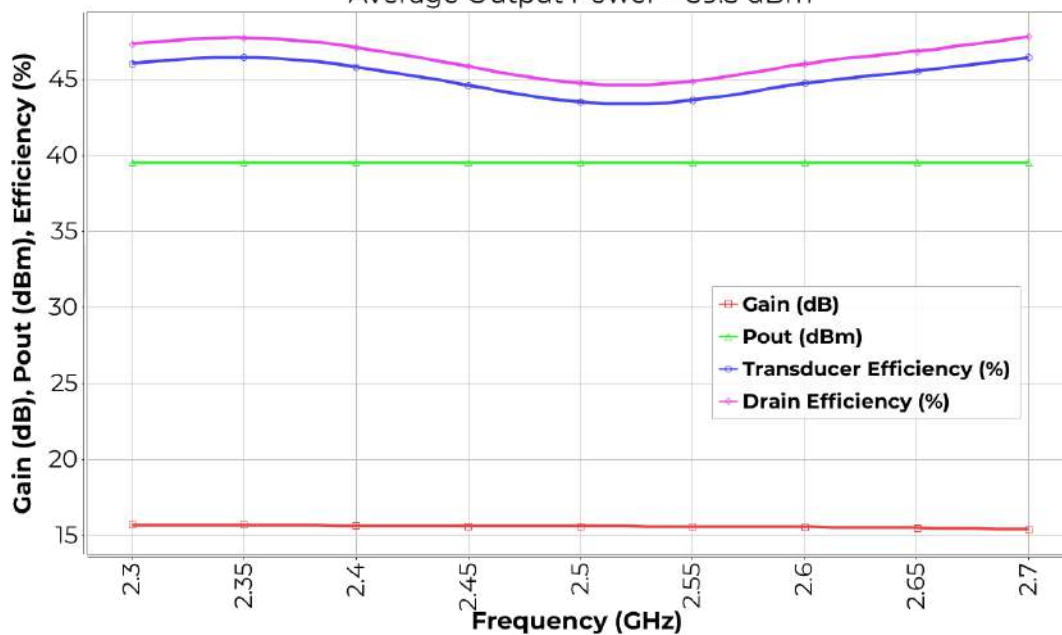

USE CASE

- Test signal: 5G NR 100MHz 2C 200MHz Frequency Division Duplex (8dB PAPR)
 - Pout = 39.5dBm
 - Sampling freq: 983.04MS/s



DOHERTY 3.7 – 4.2 GHZ

POWER AMPLIFIER KEY FEATURES

- *GaN on SiC Doherty PA*
- *Frequency range: 3.7GHz – 4.2GHz*
- *Drain efficiency: >46% at 8dB Output Back Off (OBO)*
- *Output power at P3dB = 47.5 dBm*
- *Power gain: 12dB*
- *Board size: 40x40 mm*

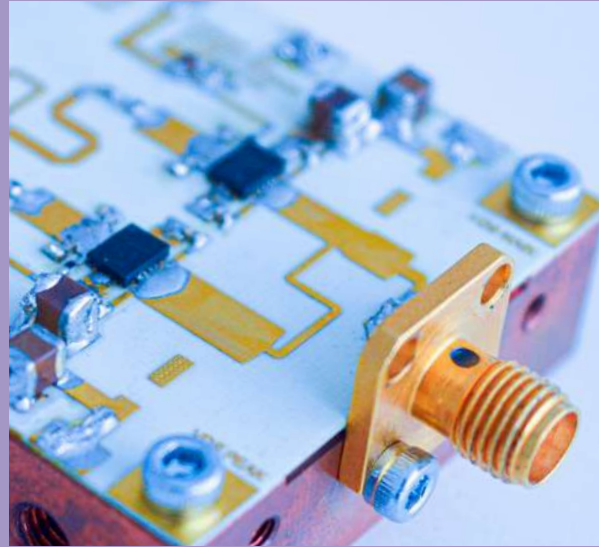

TYPICAL APPLICATIONS

- 3GPP 5G NR FR1 bands n77 and n78
- Time Division Duplex systems
- Microcell Base Station
- Small cells for wireless communications infrastructure
- Satellite Communications
- Fixed Wireless Access (FWA)
- MIMO Applications





RF pulsed characterization: 100 μ s, 10% Duty Cycle Final Stage Drain Efficiency

PA Performances

RF Pulse Characterization: 100 μ s, 10% Duty Cycle

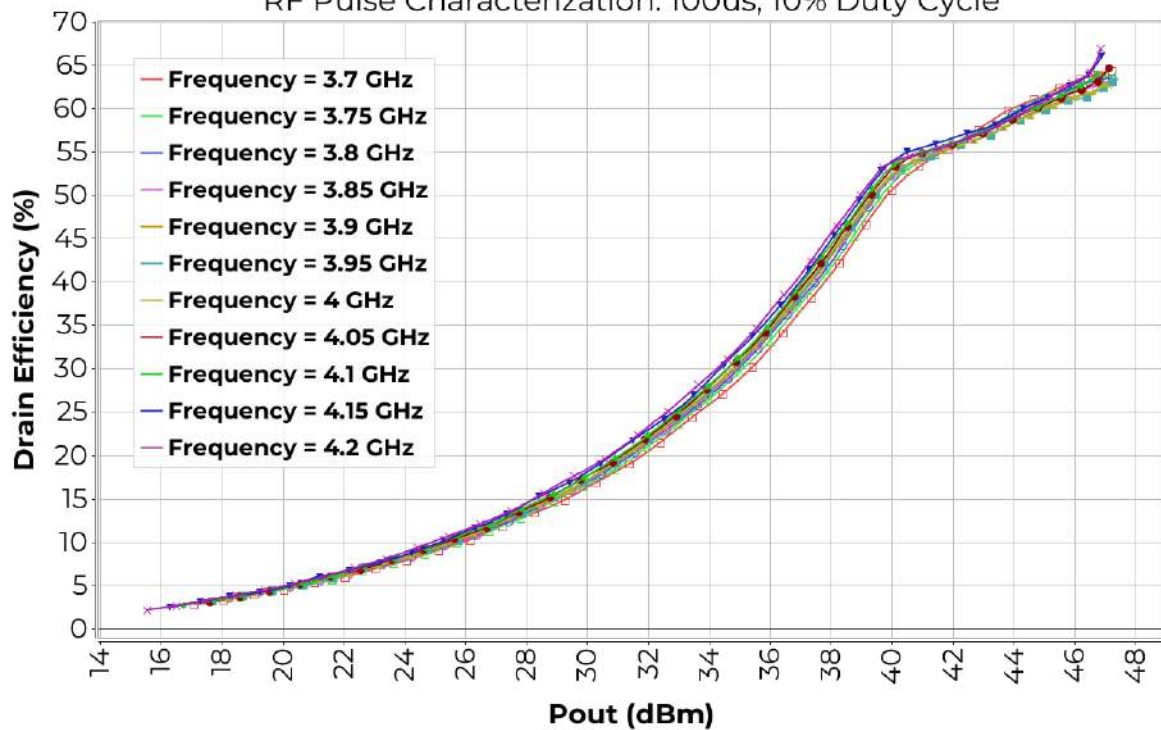

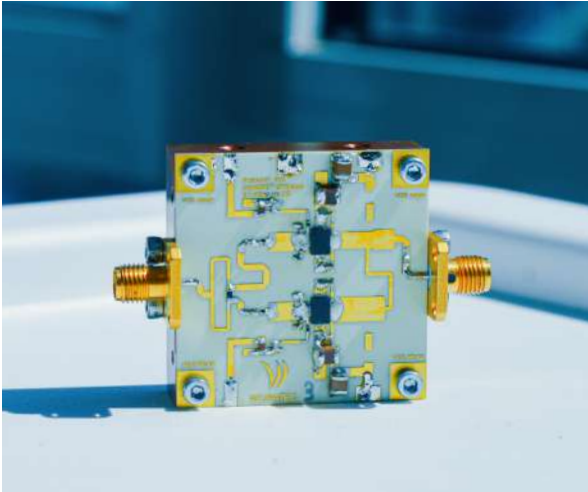

AMPLIFIER PERFORMANCES

- Test signal: 5GNR 100MHz 2C 280MHz Frequency Division Duplex (8dB PAPR)
- Pout = 39.5dBm
- ADRV9009 test platform controlled by IQsta

PA Performances at Average Power = 39.5dBm

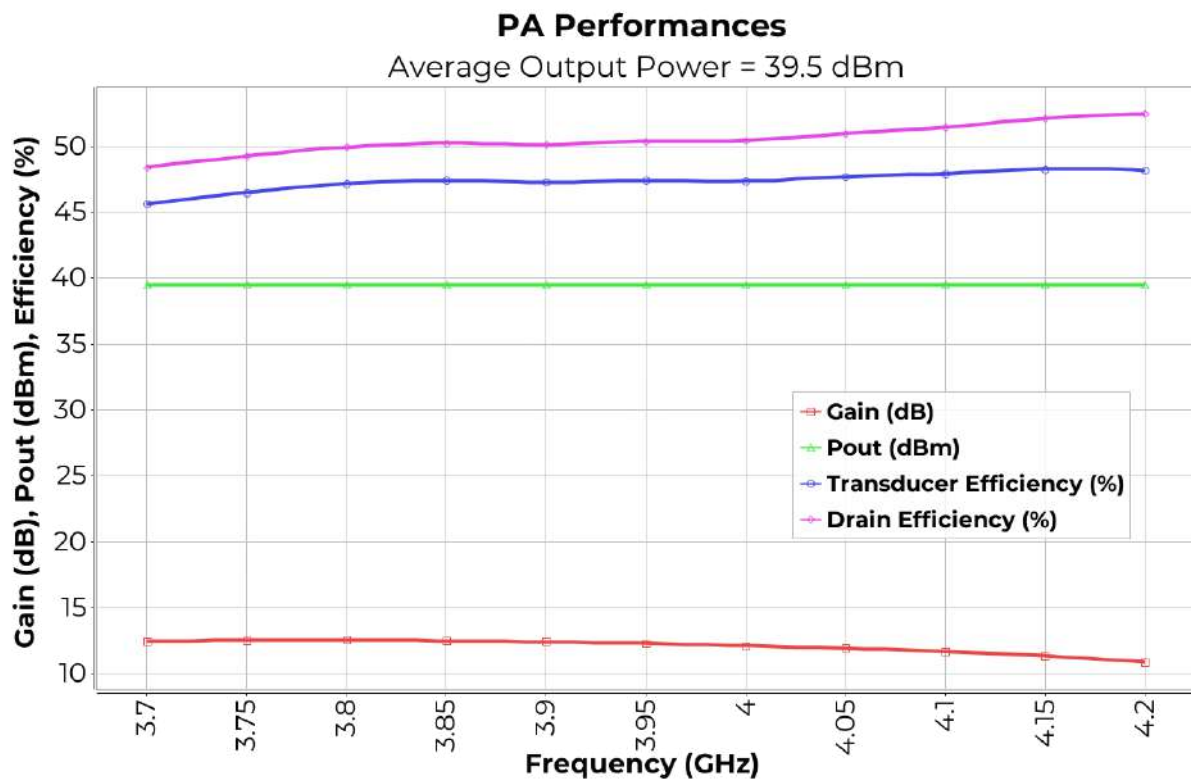

USE CASE

- Test signal: 5GNR IOOMHz 2C **280MHz Time Division Duplex (8dB PAPR)**
 - Pout = 39.5dBm
 - Sampling freq: 983.04MS/s



2-STAGE DOHERTY 3.7 – 4.2 GHZ

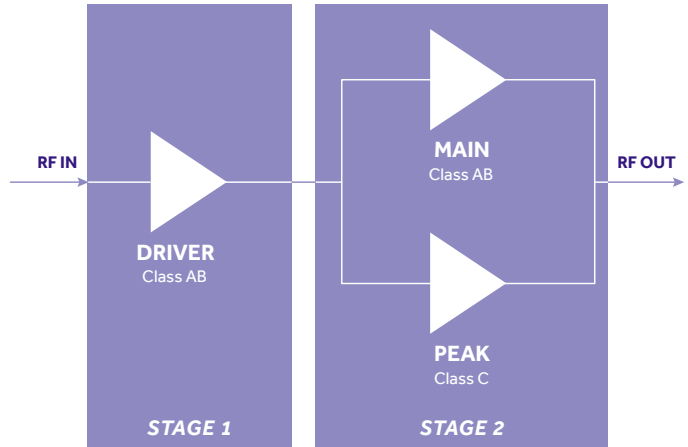

POWER AMPLIFIER KEY FEATURES

- GaN on SiC transistors, 2 stages
- Frequency range: 3.7GHz – 4.2GHz
- PAE: 42% at 8dB output back off
- Output power at P3dB = 47.5 dBm
- Power gain: 31dB
- Board size: 60 x 40 mm

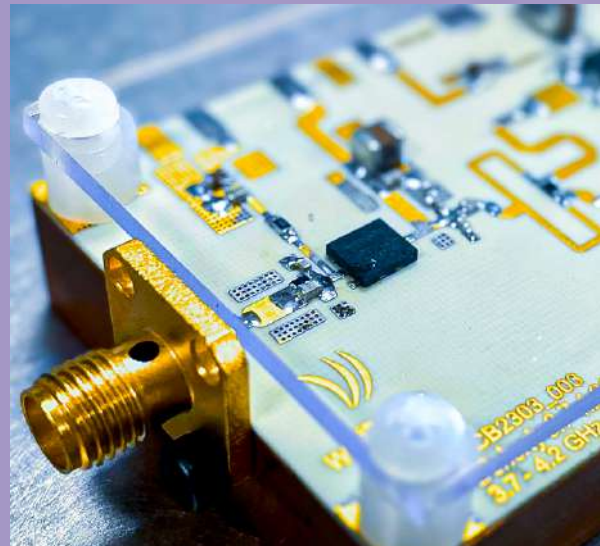

TYPICAL APPLICATIONS

- 3GPP 5G NR FR1 bands n77 and n78
- Frequency Division Duplex and Time Division Duplex systems
- Microcell Base Station
- Small cells for wireless communications infrastructure
- Satellite Communications
- Fixed Wireless Access (FWA)
- Private Networks
- Public Safety and Critical Communications
- General purpose wireless applications
- MIMO Applications



RF pulsed characterization: 100 μ s, 10% Duty Cycle Final Stage Drain Efficiency

PA Performances

RF Pulse Characterization: 100 μ s, 10% Duty Cycle

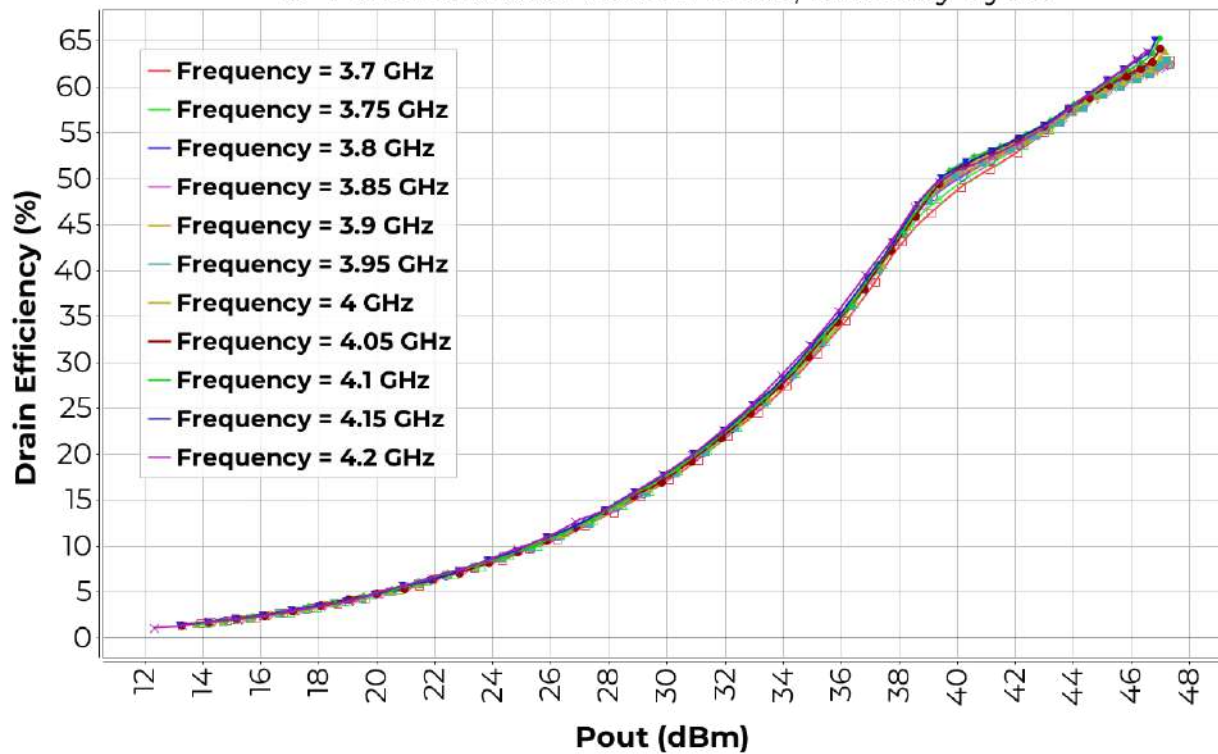

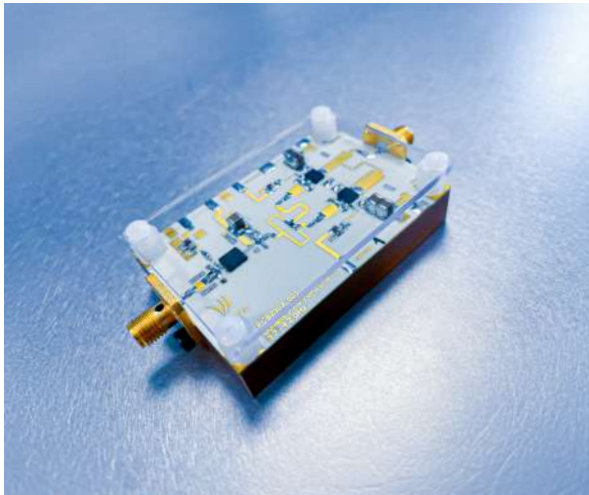

AMPLIFIER PERFORMANCES

- Test signal: 5GNR 100MHz 1C **100MHz Frequency Division Duplex** (8dB PAPR)
- Pout = 39.5dBm
- **Xilinx RFSoc ZCU670 test platform controlled by IQstar**
- Sampling freq: 983.04MS/s

Spectrum Trace

Test signal: 5G NR 100MHz 1C 100 MHz FDD (8dB PAPR)

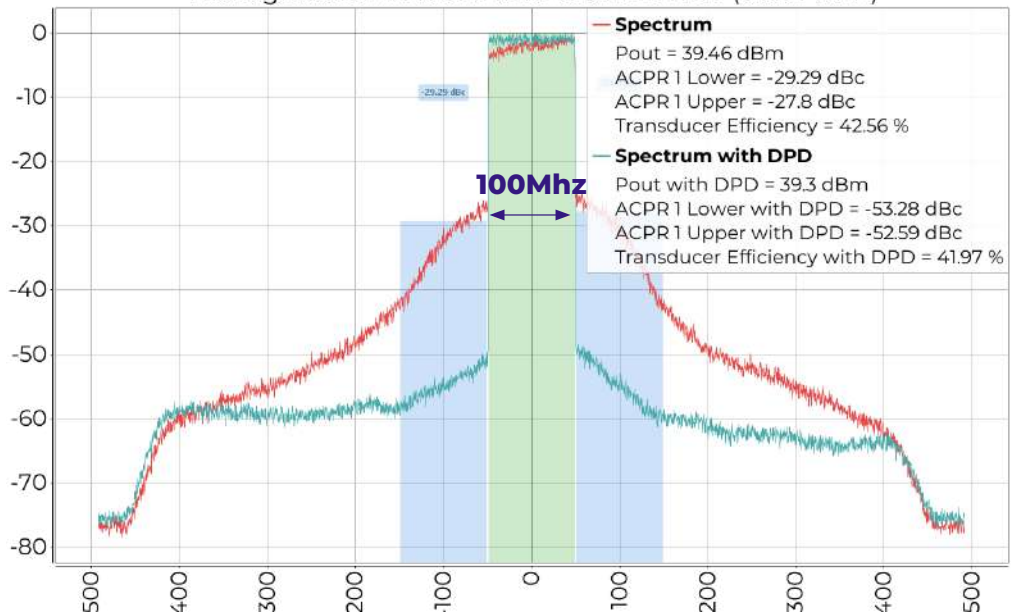

PA Performances

Average Output Power = 39.5 dBm

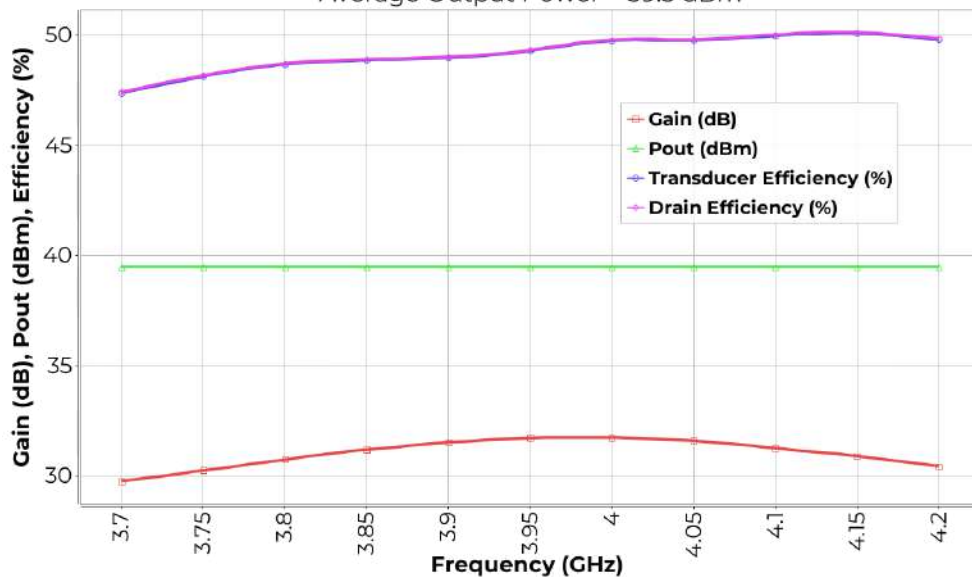

USE CASE

Test signal: 5GNR 100MHz 2C **400MHz Frequency Division Duplex (8dB PAPR)**

- Pout = 39.5dBm
- Sampling freq: 1638.4MS/s



TIME DIVISION DUPLEX MODE USE CASE

- Test signal: 5G NR 100MHz 4C 400MHz TDD (8dB PAPR)
- Pout = 39.5dBm
- Sampling freq: 1638.4MS/s

Xilinx RFSoc ZCU670 test platform controlled by IQstar



Acq. window at burst start



2-STAGE DOHERTY 3.3 – 4.2 GHZ

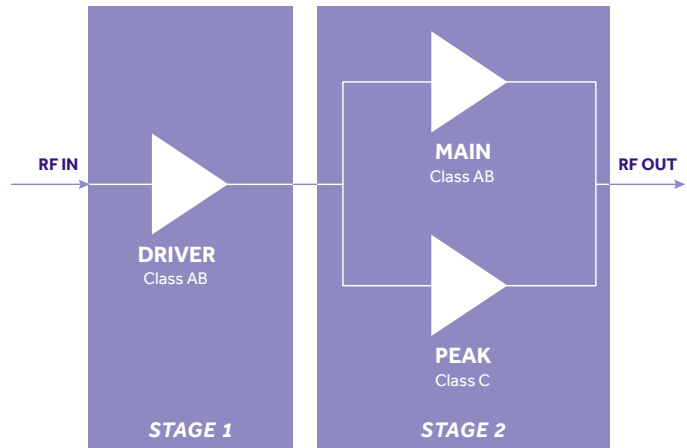

POWER AMPLIFIER KEY FEATURES

- GaN on SiC transistors, 2 stages
- Frequency range: 3.3GHz – 4.2GHz
- PAE: 35% at 8dB Output Back Off (OBO)
- Output power at P3dB = 47.5 dBm
- Power gain: 29dB
- Board size: 60 x 40 mm

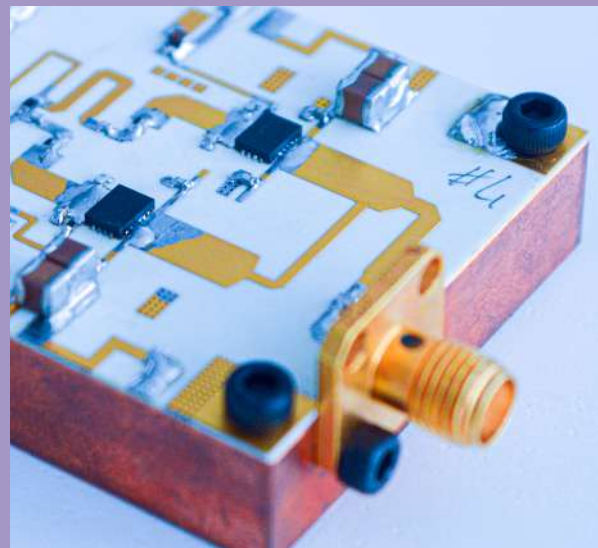

TYPICAL APPLICATIONS

- 3GPP 5G NR FR1 bands n48, n77, n78
- 3GPP 4G LTE bands 42, 48, 49 and 52
- Frequency Division Duplex and Time Division Duplex systems
- Microcell Base Station
- Small cells for wireless communications infrastructure
- Active antennas
- Land Mobile and Military Radio Communications
- General purpose wireless applications
- MIMO Applications





RF pulsed characterization: 100 μ s, 10% Duty Cycle Final Stage Drain Efficiency

PA Performances

RF Pulse Characterization: 100 μ s, 10% Duty Cycle

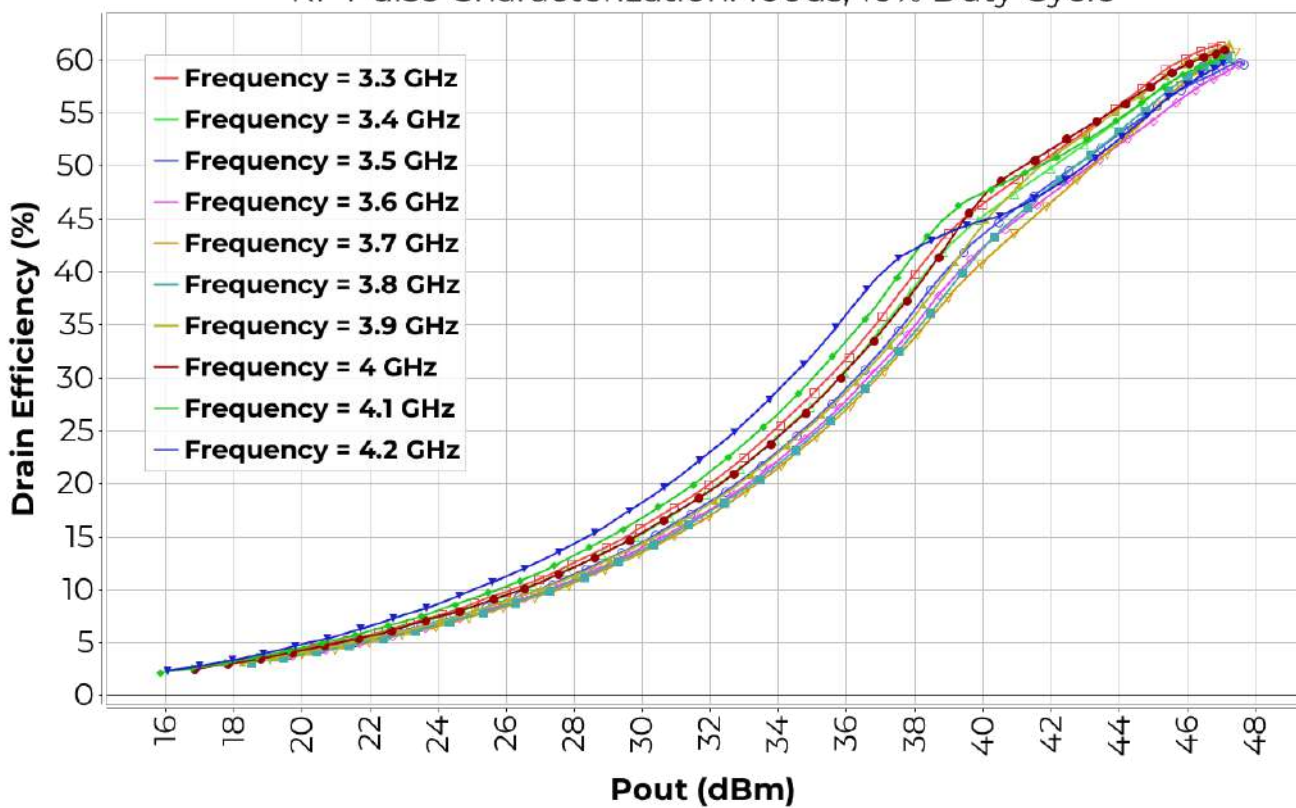

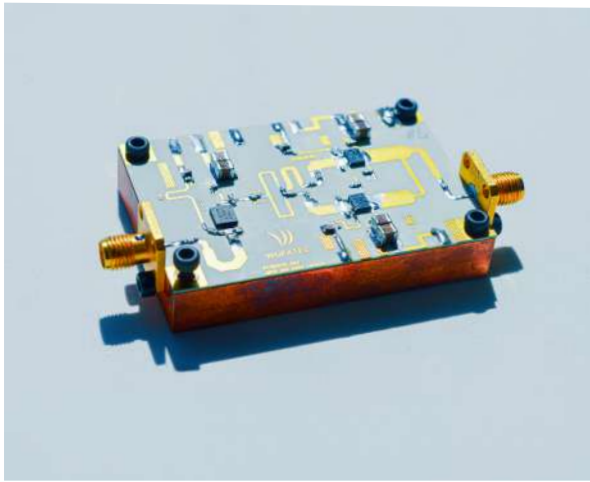

AMPLIFIER PERFORMANCES

- Test signal: 5GNR 100MHz 1C **100MHz Frequency Division Duplex** (8dB PAPR)
- Pout = 39.5dBm
- **Xilinx RFSoc ZCU670 test platform controlled by IQstar**
- Sampling freq: 983.04MS/s

Spectrum Trace

Test signal: 5G NR 100MHz 1C FDD (8dB PAPR)

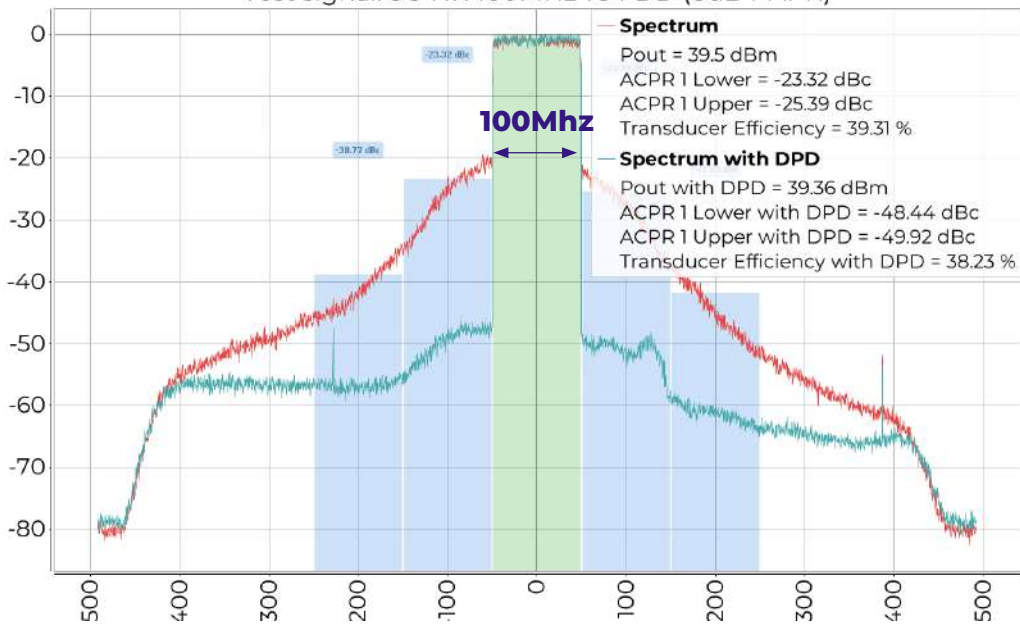

PA Performances

Average Output Power = 39.5 dBm

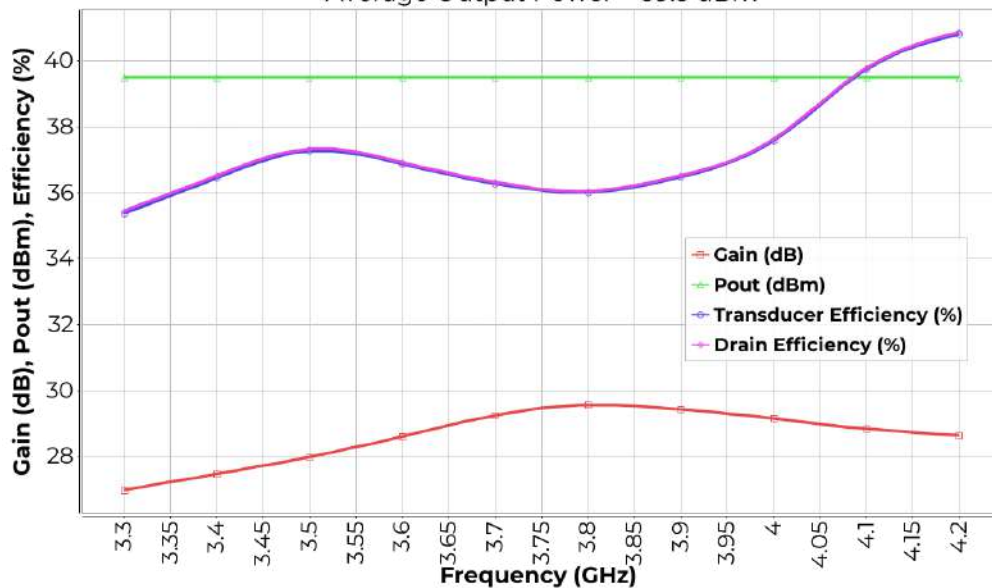

USE CASE

- Test signal: 5G NR 100MHz 2C 600MHz Frequency Division Duplex (8dB PAPR)
 - Pout = 39.5dBm
 - Sampling freq: 2457.6MS/s

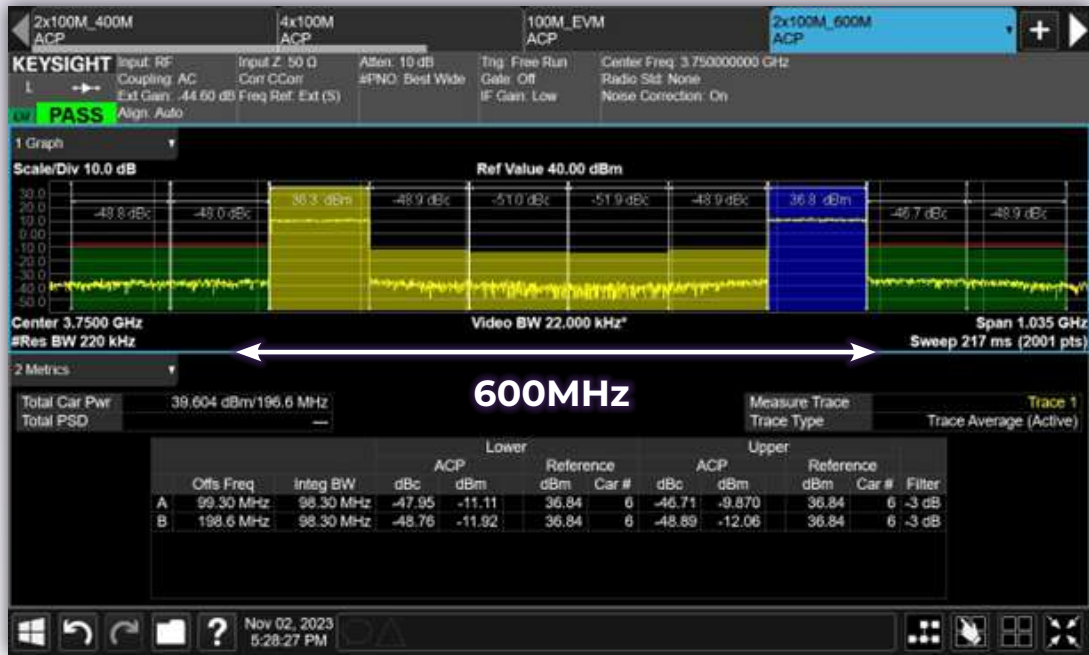

TIME DIVISION DUPLEX MODE USE CASE

- Test signal: 5G NR 100MHz 4C 400MHz TDD (8dB PAPR)
 - Pout = 39.5dBm
 - Sampling freq: 1638.4MS/s

Xilinx RFSoc ZCU670 test platform controlled by IQstar



Signal power at 3.805GHz vs. Time





SECTION 02

AMPLIFIER MODULES

At Wupatec, we provide cutting-edge RF power amplifiers to create robust and efficient transmit modules. Depending on the client's specifications, we can offer a wide book of options featuring efficiency and linearity over large bandwidths, making them ideal for use in a range of applications covering all major 5G frequency bands. Our modules meet the most demanding requirements of today's communication systems. They can be adapted for the telecom, radar, or satellite communication standards.

Prior projects have allowed us to effectively overcome common challenges like stability or heat dissipation, arriving at precise values of transmission gain. This has served as a step along the learning process for creating high-performance amplifier modules.

Since Wupatec can develop the entire module from beginning to end—that is, all of the amplifiers in the transmit module are designed internally—the finished product is compact and unique, tailored to the exact needs of the client.

AMPLIFIER MODULES

AMPLIFIER MODULE KEY FEATURES

*To be defined
depending on
clients' needs*

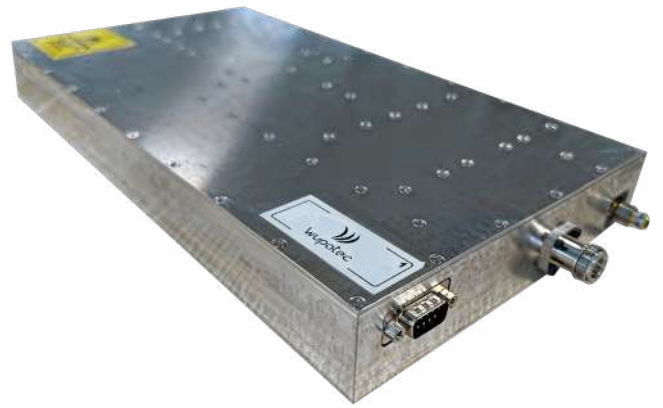

TYPICAL APPLICATIONS

- Telecommunications infrastructure (4G/5G/LTE)
- Broadcast transmitters (TV and FM radio)
- Radar systems (military, surveillance, and weather)
- Satellite communications (uplink/downlink amplification)
- Electronic warfare and signal jamming
Wireless communication systems (Wi-Fi, IoT, Bluetooth)
- Medical imaging equipment (MRI, ultrasound)





SECTION 03

TEST PLATFORMS

Optimize your RF power amplifier tests and characterization with our advanced RFSoc-based test platforms, now enhanced with IQSTAR software integration. This powerful combination enables comprehensive power amplifier measurements, dramatically reducing the PA circuit design cycle by allowing multiple tests within a single, compact platform. Ideal for evaluating Doherty, Class AB, and balanced power amplifiers, our testbenches support a wide range of circuit topologies and amplifier technologies, including GaN and LDMOS.

With capabilities for CW and pulsed signal generation to measure power, gain, and added efficiency, as well as 2-tone characterization for assessing video bandwidth, this platform is perfectly suited for in-depth PA analysis. Additionally, the system supports LTE/5G modulated signal characterization, enabling precise evaluation of linearity under Digital Pre-Distortion (DPD) conditions.

Measure ACPR, EVM, power, and efficiency with complex modulated signals—all in one streamlined, high-performance test solution.

AM9009 TESTBENCH

75MHz-6GHz Vector Signal Transceiver for Power Amplifier Test

VECTOR SIGNAL TRANSCEIVER MAIN FEATURES

- *RF Frequency: 75 MHz - 6 GHz*
- *Bandwidth: Up to 400 MHz*
- *Integrated vector signal generator/analyzer*
- *Supports 1-tone CW, 2-tone, IQ modulation for PA tests*
- *Configurable pulse rise/fall times in pulsed CW mode*
- *Auto attenuator settings for high accuracy*
- *Averaging up to 8192 for high dynamic range*
- *Trigger and 10 MHz IN/OUT for external devices*
- *High data transfer via Gigabit LAN*



SPECIFICATIONS



- **75MHz-6GHz RF VST** based on **ADI ADRV9009** boards
- Turnkey **IQSTAR measurement software**
- Dedicated **firmware** for **benchtop-grade** VST operation
- RF Power Amplifier **characterization** under **base station conditions**:
 - **LTE/5G PA tests** up to **400MHz bandwidth**
 - **1-tone**: CW and **pulsed CW** with adjustable **rise/fall time**
 - **2-tone**: Video **bandwidth analysis**

Power Amplifier test platform description

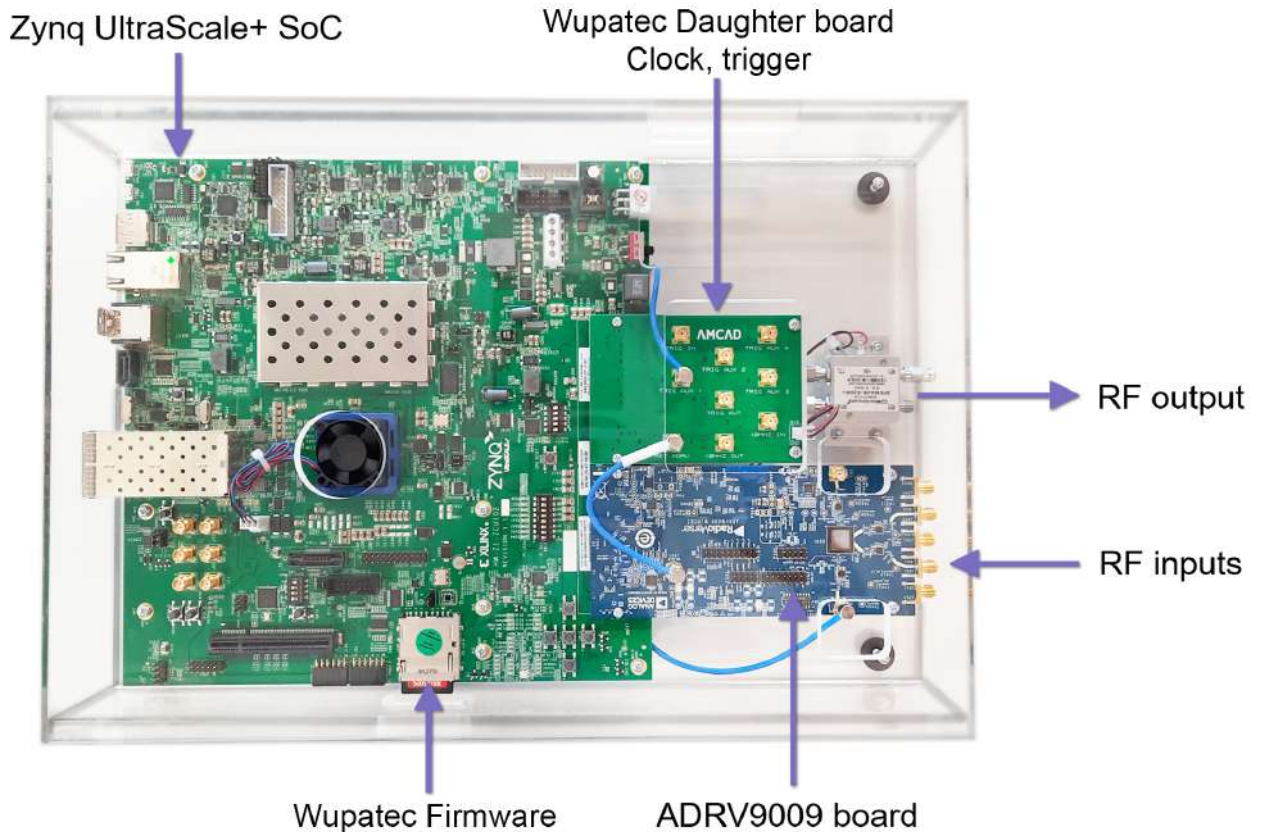

XILINX RFSOC PA TEST BENCH

with Wupatec's Firmware

WUPATEC FIRMWARE FOR XILINX RFSOC FEATURES

- *Controlled via Ethernet with a computer running IQStar*
- *Instrument power up with simple ON/OFF button*
- *Live center frequency change from 10MHz to 7.125GHz*
- *Live sample rate change from 122.88MS/s to 983.04MS/s (planned up to 1966.08MS/s)*
- *Calibrated output power*
- *Generation and acquisition of long test models waveforms LTE and 5G NR (TM1.1, TM3.1, TM3.1a)*
- *Live selection of on-board DPD:*
 - *Wupatec DPD*
 - *Xilinx DPD and CFR*
- *Multiple PA characterization modes:*
 - *IQ waveform*
 - *2 tones*
 - *CW / pulsed CW*

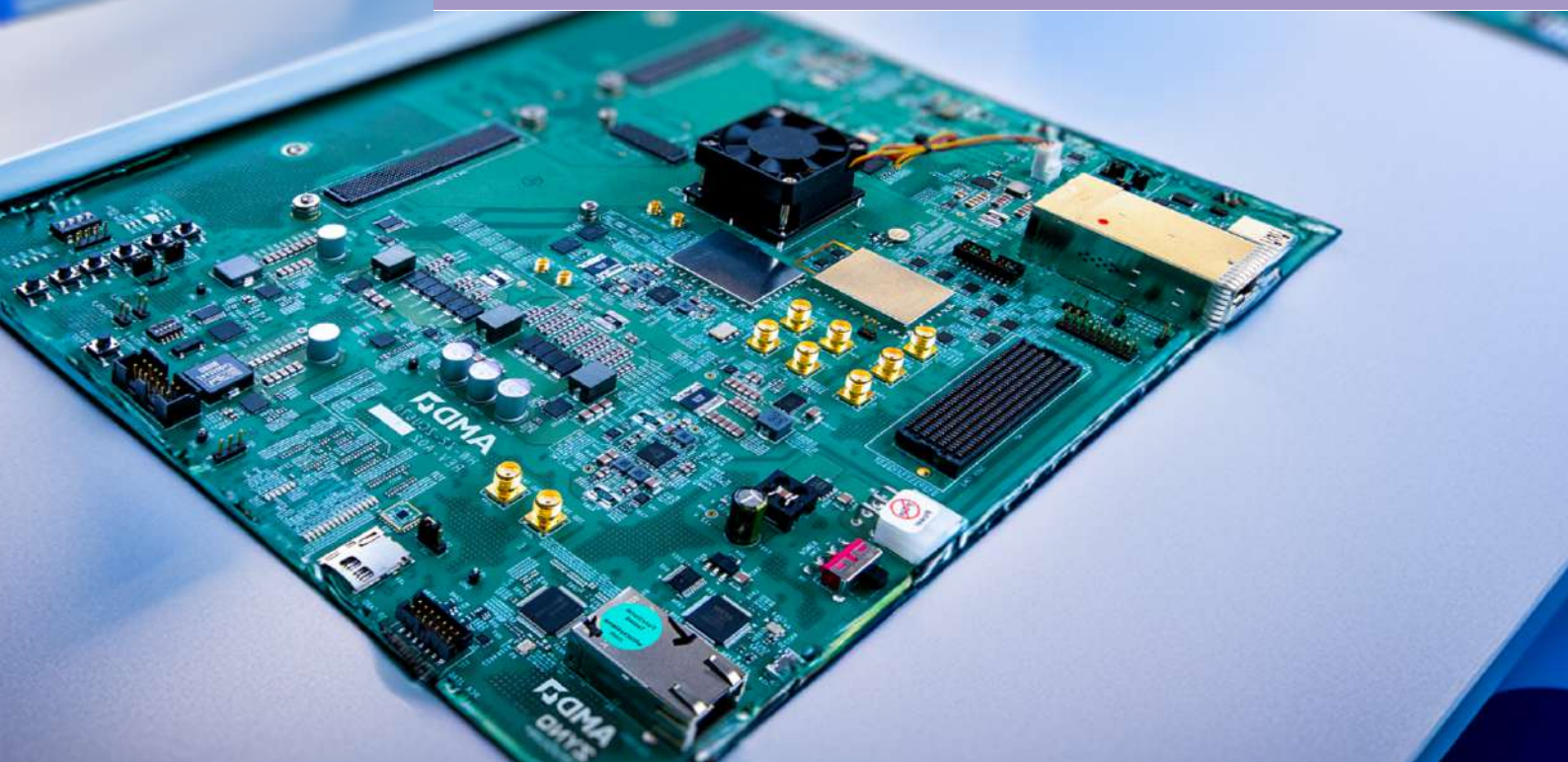

SPECIFICATIONS



- **10MHz-7.125GHz Vector signal Transceiver (VST)** based on AMD RFSoc DFE ZCU670 evaluation kit
- **Dedicated firmware to run the VST like a benchtop instrument grade solution**
- **Measurement of RF Power Amplifier in base station-like conditions:**
 - **LTE/5G PA** Tests with signal generation and analysis bandwidth up to **1.95GHz**
 - **1-tone measurements** : CW & pulsed CW, characterization with configurable rise/fall time
 - **2-tone measurements** for video bandwidth analysis
 - **IQ signal generation/analysis**
 - Embedded AMD CFR & DPD IP
- **Trigger and 10 MHz IN/OUT available to connect power meters, multimeter or spectrum analyzer**

Xilinx RFSoc with Wupatec Firmware

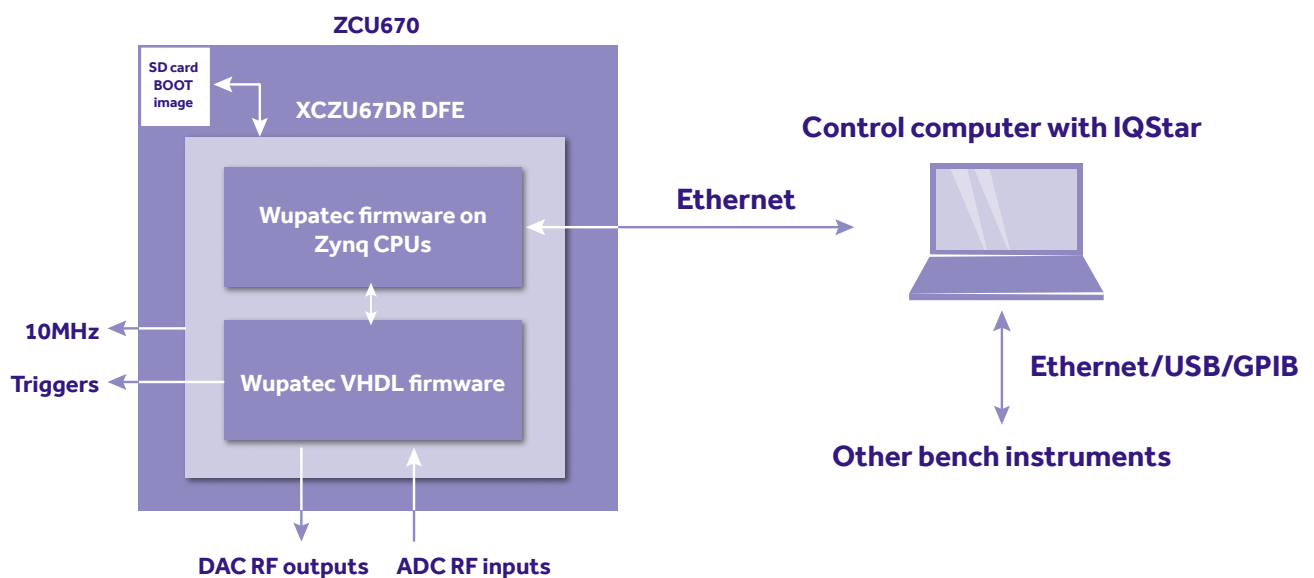

COMPLETE RFSOC TEST CONFIGURATION

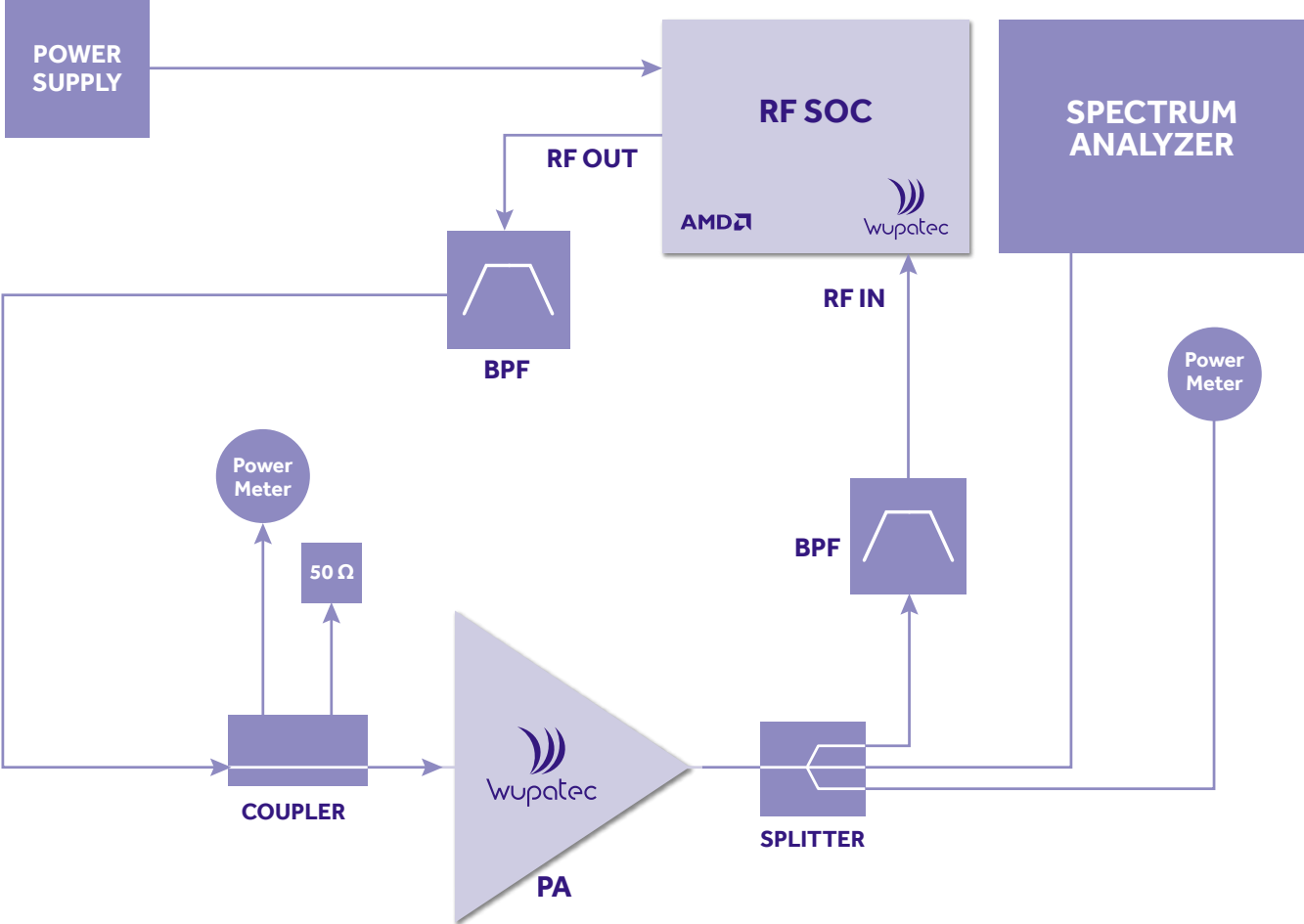



CONTACT

WUPATEC

Bâtiment Galiléo
20 rue Atlantis
87068 LIMOGES
FRANCE

WUPATEC Toulouse

Le California - Batiment B
1244 L'Occitane
31670 LABEGE
FRANCE

Phone: +33 555 426 244
Email: contact@wupatec.com